



PHILIPS

NaturalTrust
UVC LED Module

Philips NaturalTrust UVC LED module

The small solution for clean water



Philips NaturalTrust UVC LED Module for **clean water**

Philips is launching the first NaturalTrust solution based on UVC LED technology

The first NaturalTrust solution is a module which is designed to fit in a water reservoir. It emits UVC radiation which deactivates bacteria, viruses and other micro-organisms to prevent them from growing. The module disinfects water and the reservoir walls. It also reduces the presence of unpleasant odors and germs accumulating in your device, therefore requiring less maintenance. Because of its small size, it fits appliances where conventional mercury discharge lamps cannot be integrated, such as refrigerators, coffee machines, air humidifiers, ice makers etc.

Successful operation of the UVC LED module has been proven by monitoring microbiological test setups in real environments for several months of continuous operation. This resulted in a 99% reduction of bacteria without the need for cleaning the device.

Features	Benefits
Reduces microbiological contamination by 99%	Clean water
Silicone snap fit housing	Plug & play and compact sealed-to-water solution for reservoirs
On board electronics	Output independent from input voltage
Low power	Minimal energy consumption
Contains no mercury	Environmentally friendly
Instant on	Instant disinfection

Philips NaturalTrust UVC LED Module

Dimensional drawings

Snap version

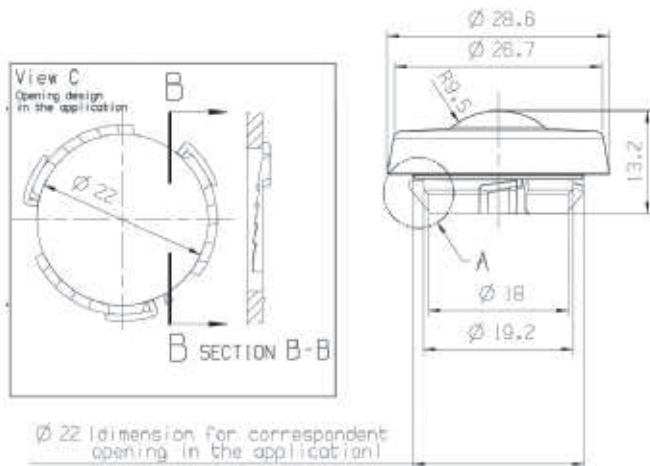

Nut version

Wall thickness of application: 1.2 - 3 mm

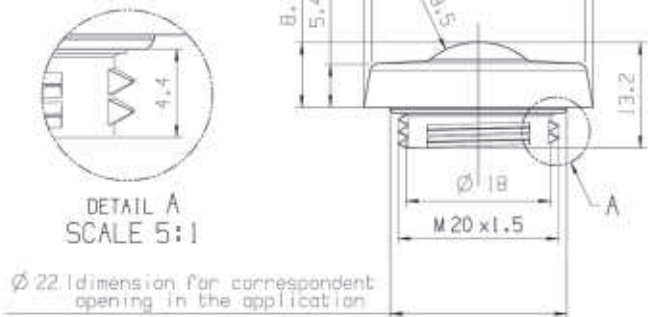

Dimensions in mm

Technical specifications

Module specifications

Supply voltage	12 – 24 VDC
Input current	Depending on input voltage, max 90mA
Module power consumption	Max 0.8 W
IEC 62031	As 'Built-in LED Module'
UL: Registered Component	UL 979, C22.2 No. 68-09



UVC LED Module snap version



Module performance in water at Tc=30 °C after 100hr operation

UVC output	7.4mW Note: the UVC output does NOT depend on the input voltage	
Max radiation at wavelength	278 nm +/- 5nm	
UVC maintenance (L50B10)*	Tc = 40 °C --> 10000 operational hours Tc = 65 °C --> 7000 operational hours	
Temperature limits (continuous operation) without cooling	Operated in water	Operated in air
	Water temperature 40 °C Air temp backside module 55 °C (non ventilated)	Air temp back/front module 25 °C (non ventilated)
Operation temperatures	Tc : max. 65 °C	
Maximum humidity	85%	

Notes:

- Use additional cooling of the device to reduce operating temperature.
- When air or water flows around the module, due to ventilation for example, lifetime will be longer.
- Any water condensation on the pcb is not allowed. Lifetime and UVC output will be negatively influenced when operating in high humidity environment.

* 10% of the products will have 50% of the initial UVC output at the declared lifetime. 90% of the products will have higher UVC output. When the module is operated below these operation temperatures, the UVC output remains > 50% for > 7500 hours for > 90% of the modules. If the module is operated at temperatures above, the L50B10 point may be < 7500 hours, and product failures may occur.

Connector specifications*



Connector Molex "PicoBlade" 51021-0200 Polarity**	Terminal 2 (black): 0 VDC, Terminal 1 (red): 12-24 VDC WARNING: The module is not protected for inverse polarity
Rated current and voltage	1.0 A max, 125 VAC (r.m.s)
Dielectric Withstanding Voltage	250 VAC for one minute
Contact Resistance	< 20 mOhm
Insulation Resistance	> 100 MOhm
Durability (mating cycles max)	30
RoHS Compliant	
Non Halogen Free	

* not part of product offering

** if different connector is used, make sure the above requirements are being fulfilled

Location of Tc

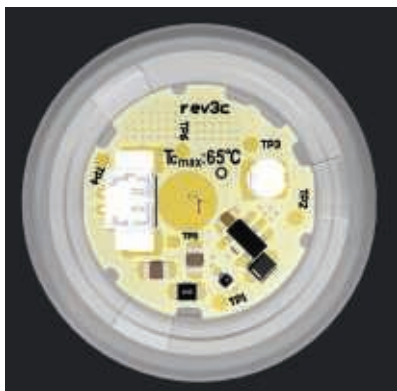

Spectral irradiance UVC Module

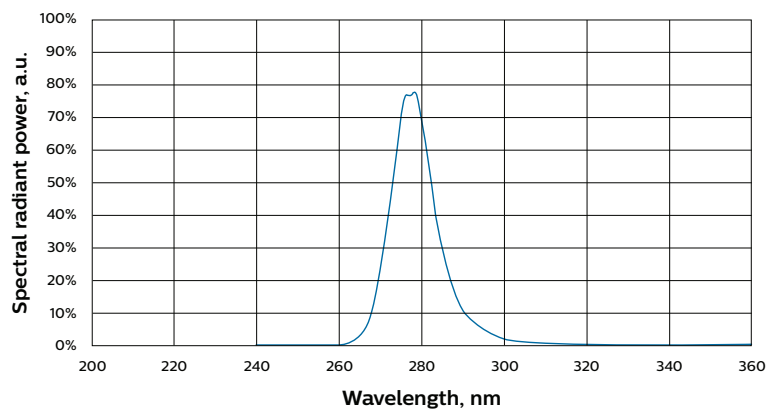

Continuous use: allowed when Tc < 65 °C | Number of switches: minimal 100.000

Water tightness & dust ingress

IEC standard 60529	IP68 (from silicone side)
Maximum working pressure	No water leak at 50 psi / 3,5 bar
Cycling water pressure	Tested for 0 mbar / 250 mbar

Philips reliability tests

Characteristic checked	Test or inspection items
Reliability non operational	Temperature cycle IEC 60068
	Thermal shock IEC 60068
	Wet High Temperature Storage Life IEC 60068
Reliability operational module	Power and Temperature Cycling IEC 60068
	Room Temperature Operating Life time module IEC 60068
	High Temperature Operating Life LED IEC 60068
	Room Temperature Operating Life time LED IEC 60068
	Switching cycles
Design in	Thermal management
	Corrosion Test
	Field tests
	Microbiological performance
	Materials release in appliance
Mechanical tests/ water sealing	Sinusoid vibration JESD 22-B103
	Random vibration JESD 22-B103
	Mechanical impact
	IP level IEC 60529:2003
	Low pressure water
Sustainability	Material compliance with RoHS / Reach
Electrical safety	IEC 61347
	IEC 62031
Electro Magnetic Compatibility	Radiated Electromagnetic Disturbance EN55015:2013
	Radio Frequency Electromagnetic Field EN55015:2013
	Electrostatic discharge EN61547:2009 / EN61000-4-4:2009
	Electromagnetic Field Immunity EN61547:2009 / EN61000-4-3:2007
Packaging	Drop test ISO 2248
	Transportation test (for shipped finished products)
Approbation	CE safety: CB report available
	UL 979
Drinking water and food contact compliance	Closures with sealing gaskets for food containers 21 CFR 177.1210 FDA
	Rubber articles intended for repeated use 21 CFR 177.2600 FDA
	(EC) 1935/2004 and German LFGB

Data subject to change

